



**iLOCK**

# SISTEMAS DE CIERRE ELECTRÓNICO ELECTRONIC LOCKING SYSTEMS

## CEM Furniture electronic lock with RFID

The CEM "contactless" furniture electronic locks stand out for being easy to use and with motorized opening and locking. It is a standalone solution, battery operated and cable free.

The best solution for locker/drawers/showcases/wardroves for:

- Shops, supermarkets, shopping centres...
- Pharmacies, hospitals, universities, office buildings...

WE MAKE  
SENSE

**ENKOA**



# CEM FURNITURE ELECTRONIC LOCK WITH RFID



## Characteristics

DESCRIPTION	Furniture electronic lock contactless with 13,56MHz RFID.
REFERENCE	CEMxxM1xxGx0
POWER	1 battery CR123A, 3V
BATTERY LIFE	2 years
RFID FREQUENCY	13.56MHz.
READING DISTANCE	20 mm.
INTERFACE	Beeper.
OPERATING TEMPERATURE	-10° to 60°
DIMENSIONS	Height 62, Width 62 and depth 34mm.
WEIGHT	86 gr.

## Dimensions

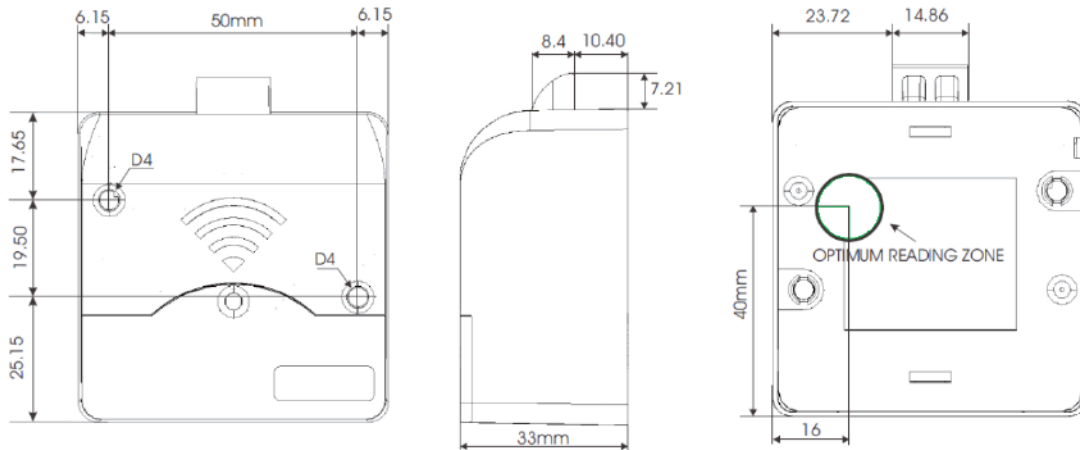

## Benefits

**CONTACTLESS:** Opening by approaching an authorized card. Temporized locking or by approaching a card.

**STANDALONE:** Without cables, battery operated.

**CONCEALED:** It remains hidden behind the furniture door, being very esthetic.

**FREE/ FIX ASSIGNMENT MODES.**

**MASTER CARDS:** Master cards can be generated for opening and locking any of the lockers.

**MULTIPLE OPENING. AUTOMATIC OPENING.**

**AUDIT TRAIL BY USING A CARD.**



Enkoa System S.L.

Polígono Erramone 45, 20850 Mendaro. Gipuzkoa. Spain  
 T +34 943 757 000 | info@enkoa.com  
[www.enkoa.com](http://www.enkoa.com)

